

DeltaSuit User Manual

AUXIVO

Index

Introduction	
Purpose of these instructions	1
Description of the user	1
Getting started	2
Conventions used in this manual	2
Explanation of safety warnings	2
Product safety signs	3
Retaining instruction handbook	3
Important information for the employer	3
Information and support	4
Description	
Intended use and reasonably foreseeable misuse	5
How the DeltaSuit works	5
What kind of work is supported?	6
What kind of work is not supported?	6
What if my work includes multiple tasks described above?	6
Product elements	7
System components	8
Technical specifications	9
Safety instructions	
Important safety information	10
What to do in case of an emergency and exceptional situations	11

Index

Preparation and Use	
Unpacking the DeltaSuit	12
Checking the DeltaSuit	12
Preparing the DeltaSuit	13
Adjusting the support level	14
Putting on the vest	15
Unlocking the shoulder joints and donning the arm cuffs	16
Adjusting the shoulder joint position	17
Checking and adjusting for an optimal fit	18
Securing loose straps	18
Taking off the DeltaSuit in the right order	19
Cleaning, Care and Maintenance	
General care	20
Inspections	20
Cleaning the DeltaSuit	21
Multiple Users for one DeltaSuit	23
Disposal	23
Legal Information	
Liability	24
Warranty	24

Purpose of these instructions

Thank you for purchasing the DeltaSuit. The purpose of this document is to make you familiar with the installation and use of the DeltaSuit, so that you can safely operate it. This documentation should therefore be regarded as an integral part of the DeltaSuit.

Description of the user

These instructions are primarily intended for the end-user of the DeltaSuit and secondary for the employer of the end-user. The end-user can be described as each person who interacts directly with the system. The end-user typically includes, but is not limited to:

- Installer
- Operator
- Maintenance personnel or technicians

The DeltaSuit reduces the load on your back, neck and shoulder muscle by equipping you with “external” back and shoulder muscles. While the forces on your back, neck and shoulders are not expected to increase when wearing the DeltaSuit, as a precaution, people with health problems are not allowed to use the DeltaSuit without prior consultation with a medical professional.

Everyone else can use the DeltaSuit. However, you shall never conduct any work while wearing the DeltaSuit that would not be considered safe to conduct without the DeltaSuit, e.g. working with tools which are heavier than what you can handle. The DeltaSuit does not make you immune to injuries.

All use of the DeltaSuit shall only be carried out by an authorized and a properly qualified and skilled person of 18 years or older, who:

- Has read and understood this manual.
- Knows how to control this product.
- Is aware of all possible dangers and acts accordingly.

The required maintenance and inspection work, as stated in this instruction handbook, is allowed by the aforementioned persons, unless clearly indicated when this is not allowed.

WARNING

The DeltaSuit shall not be used by people with health problems without prior consultation with a medical professional.

Getting started

Before you start using the DeltaSuit yourself, or before you hand it out to be used in your company, we advise you to take the time and read the following sections of this handbook carefully.

While the DeltaSuit is not a complicated piece of equipment, you will only benefit by using it correctly. It is a wearable device that can be connected to your body for hours. This will need some getting used to until it feels like a new natural way of working.

To get the maximum benefit from your DeltaSuit, we recommend the following steps:

1. Learn how to put it on, and how to adjust it to your body size.
2. Learn how to use it intuitively without thinking about it. Learn how to select the support level for your current task.
3. Get used to it. Do not use it for eight hours per day from the beginning. Start with one hour per day and increase over time until it feels perfectly natural.

Conventions used in this manual

The following style conventions are used in this document:

Bold	<i>Italic</i>
Warnings	Cross-references

Explanation of safety warnings

DANGER

Danger indicates a hazard with a high level of risk which, if not avoided, will result in death or serious injury.

WARNING

Warning indicates a hazard with a medium level of risk which, if not avoided, could result in death or serious injury.

CAUTION

Caution indicates a hazard with a low level of risk which, if not avoided, could result in minor or moderate injury.

NOTICE

Notice indicates information considered important, but not hazard-related.

Product Safety Signs

⚠ WARNING

Please review all safety signs which are placed on relevant parts of the DeltaSuit to indicate danger warning, pinch points, etc.

The following are safety signs, which are placed on relevant parts of the DeltaSuit.



Danger of crushing fingers



Read the manual

Retaining instruction handbook

⚠ WARNING

Read and understand this instruction handbook and its safety instructions before using this product. Failure to do so can result in serious injury or death. Keep all safety information and instructions for future reference and pass them on to subsequent users of the product.

Employers should make sure employees are informed or handed over these instructions. The manufacturer is not liable for cases of material damage or personal injury caused by incorrect handling or non-compliance with the safety instructions. In such cases, the warranty will be voided.

In case of any unclarities in the handbook, contact your supplier or Auxivo AG to avoid any misunderstanding and resulting risks.

Important information for the employer

Employers are responsible for providing a safe work environment for their employees. Therefore, they should always have conducted a task analysis, risk analysis and informed their employees about possible hazards, before they hand out the DeltaSuit in their company.

Local laws related to occupational health and safety should always be followed.

Employers should make sure all end-users have the opportunity to get used to the DeltaSuit, since it can cost time to get used to.

Information and support

The latest version of this document and other product information is available at www.auxivo.com.

To improve our customer experience, we appreciate your comments. They can be submitted on the support page of our website or sent to info@auxivo.com.

For questions, information about accessories and materials, technical assistance or ordering more instruction handbooks, please contact us:

Telephone: +41 (0) 77 250 35 31

Email: info@auxivo.com

Auxivo AG
Sonnenbergstrasse 74
8603 Schwerzenbach
Switzerland

Description

Intended use and reasonably foreseeable misuse

The DeltaSuit is intended to be used as an exoskeleton that supports the neck and shoulder muscles when performing tasks with arms at or above shoulder level. The DeltaSuit is intended to support the user and reduce the workload, for example during repetitive tasks or prolonged periods working with arms at or above shoulder level.

The DeltaSuit is not a medical device. The DeltaSuit is not intended to be used for any kind of medical application.

The DeltaSuit is not intended to be used to:

- Support other movements or other muscles than described above.
- Conduct any work that is not considered safe without wearing the DeltaSuit.
- Support you during sports or other physical activities.

For more information, see also:

- Section 7 *What kind of work is supported by the DeltaSuit?*
- Section 7 *What kind of work is not supported by the DeltaSuit?*

The DeltaSuit shall be used with original accessories and components only. Only use the DeltaSuit within the specified performance limits and accordingly to the instructions as described in this instruction handbook. All use other than described in this handbook is seen as unintended use.

How the DeltaSuit works

The DeltaSuit is designed to support your shoulder and neck muscles when you work with arms at or above shoulder level, for example, while operating a tool such as a powered drill. It functions as a layer of additional muscles on the outside of your body to reduce the load on your own muscles.

The DeltaSuit is designed to reduce the load on the neck and shoulder muscles by between 20% and 65% when you manipulate a 1.8 kg tool above shoulder level. Because your muscles work less hard, the process of fatiguing is delayed by between 45 and 75%.

The DeltaSuit features integrated elastic elements that store energy, which is then used to support the user and reduce the workload. It offers an easy-to-use, small, and lightweight support system. The user can put on the Arm cuffs whenever support is needed and take them off when not needed while keeping on the exoskeleton for later use. The user can select between two support levels (level 1 and 2) to match the current task.

Description

What kind of work is supported?

It is important to understand during what kind of work the DeltaSuit provides support and when it will not. By design, the DeltaSuit can support your neck and shoulder muscles when your arms are at or above shoulder level.

The DeltaSuit will support you each time you lift your arms, for example, when lifting an object or manipulating a tool. Consequently, you will benefit the most from the DeltaSuit if your work includes frequent work with arms raised, for example:



The DeltaSuit supports work above shoulder level, such as handling a power tool or manipulating objects above shoulder level.



The DeltaSuit supports lifting above shoulder level.

What kind of work is not supported?

The DeltaSuit is NOT designed to support other movements besides those described in section 7 *What kind of work is supported?*. It will not prevent you from doing other tasks but will not support you. Specifically, this means you cannot expect support in work involving handling loads or tools below hip level.

What if my work includes multiple tasks described above?

If your job consists of several tasks, some of which are supported and some not, you can still use the DeltaSuit. Simply put on the arm cuffs of the DeltaSuit during the suitable tasks. For unsuitable tasks, simply take off the arm cuffs and lock them behind your back.

Product elements

The DeltaSuit consists of five main elements:

1. The Vest that is connected to your upper body.
2. The Back structure that is connected to the Vest and the Shoulder structure.
3. The Shoulder structure that consists of:
 - a. Shoulder joint, which allows you to rotate your arms freely.
 - b. Lock button, which allows you to store the Arm cuff behind your back to make it easier to put on/take off the Vest and while taking a break.
 - c. DeltaSuit Elastic Energy Storage (EES), which holds the elastic bands that store your movement energy to support you when working.
 - d. Support level switch, which allows you to choose between two support levels.
4. The Arm structure that is connected to the Shoulder structure and extends in length as you move your arms around.
5. The Arm cuff that is connected to the Arm structure and your upper arm.

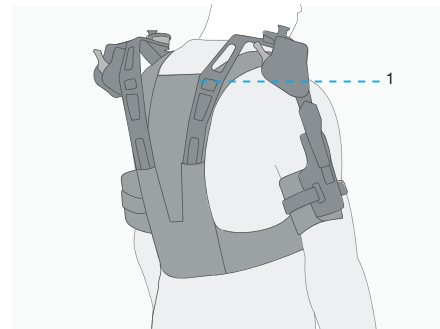
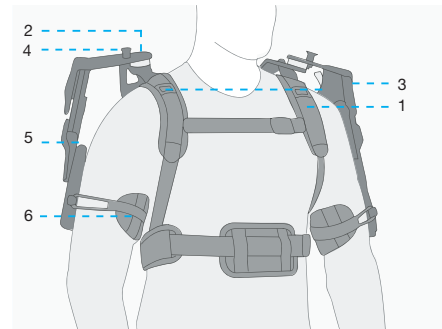

1. Back structure

Three main elements:

1. Vest
2. Shoulder joint
3. Shoulder structure
4. Lock button
5. Arm structure
6. Arm cuff

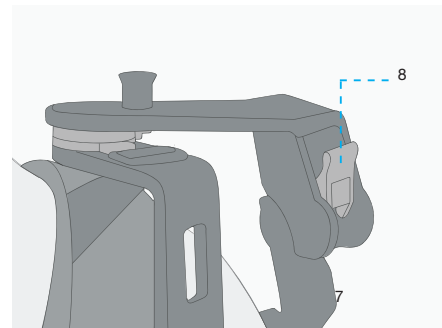

1. Support level switch

System components

For operation, maintenance and cleaning of the DeltaSuit it is important to understand how and where to locate the individual components.

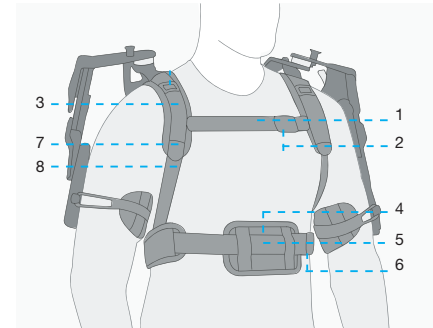

1. Upper chest belt
2. Upper chest buckle
3. Upper chest belt height adjustment buckle
4. Middle pad
5. Lower chest belt
6. Lower chest buckle
7. Vest length adjustment buckle
8. Vest length adjustment strap

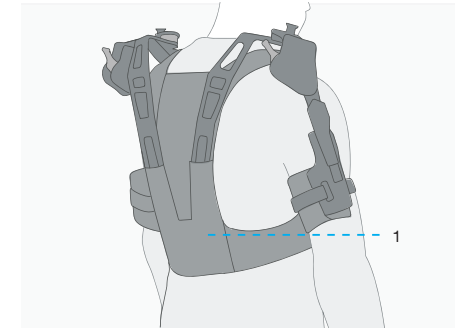

1. Vest pocket

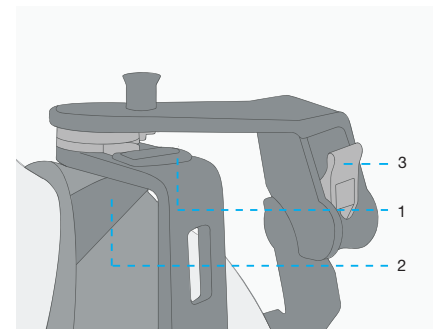

1. Shoulder attachment buckle
2. Shoulder adjustment strap
3. Support level switch

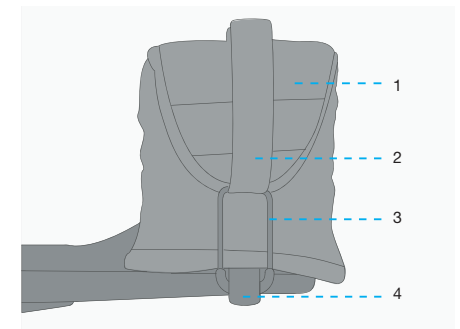

1. Arm cuff textile cover
2. Arm cuff adjustment strap
3. Arm cuff loop
4. Arm cuff hook

Technical specifications

Device name	DeltaSuit
Model	1.1
Technical life span	2 years
Size	S/M & L/XL
Size selection	User selects DeltaSuit size based on user's T-shirt size (S/M/L/XL) Note: please take into account if user wears additional thick clothing underneath the DeltaSuit
Mass overall	2.15 kg (S/M) / 2.25 kg (L/XL)
Dimensions (packed)	Approx. 26 cm x 68 cm x 23 cm
Chest circumference	57 - 97 cm (S/M) / 73 - 132 cm (L/XL)
Upper arm circumference	20 - 45 cm
Materials	Aluminium / Steel /Nylon PA12 /POM Main fabric, Spacer mesh, Lining: 100% Polyester Lining: 79% Nylon / 21% Spandex
Ambient storage temperature	15 - 25°C (59 - 77°F)

Important safety information

⚠ DANGER

Read and understand this manual and its safety instructions before using the DeltaSuit. Failure to do so can result in serious injury or death.

Do not operate the DeltaSuit in explosive atmospheric conditions, such as in the presence of flammable liquids, gases or dust. Friction between DeltaSuit materials may create sparks which may ignite the dust or fumes.

⚠ WARNING

Read and understand this manual and its safety instructions before using the DeltaSuit. Failure to do so can result in loss of functionality, including loss of support, serious injury or death.

- Never conduct any work while wearing the DeltaSuit that is not considered safe without wearing the DeltaSuit.
- Do not use the DeltaSuit if you have health problems without prior consultation with a medical professional.
- Do not use a damaged DeltaSuit.
- Do not make any changes to the DeltaSuit and its parts.
- Do not use the DeltaSuit near flammable substances. The DeltaSuit is not fire resistant.
- Keep the DeltaSuit free of any liquids, sand, dust and debris.
- Keep the DeltaSuit dry.
- Do not use the DeltaSuit when clothing according to Electrostatic Discharge standard (EN 61340-5-1) is needed to protect electronic devices.
- Inspect the DeltaSuit shoulder Elastic Energy Storage monthly and when there is wear or tear please contact your supplier or Auxivo AG.
- Use the DeltaSuit only for its intended purpose. For more information, see section *↗ Intended use and reasonably foreseeable misuse*.
- Do not do things that you would not do without the DeltaSuit.
- Do not use the DeltaSuit during work with a risk of falling forward.
- Do not wear the DeltaSuit during work that requires the use of fall protection equipment.
- The DeltaSuit is not a safety harness that protects you from falling. Put on the required fall protection before work.
- Make sure to use the correct size and that the DeltaSuit is adjusted properly before every use. Safe and effective use of the DeltaSuit relies on a proper fit to the body.
- Make sure that the DeltaSuit is properly handled and stored, e.g. do not throw onto the ground or store in an enclosed space when damp or wet.
- Consider that the DeltaSuit extends the body and can cause collisions with the environment.
- Do not place or carry any objects on top of any parts of the DeltaSuit.
- Stop using the DeltaSuit when experiencing signs of overheating, like heavy sweating, dizziness or fatigue.

CAUTION

Read and understand this manual and its safety instructions before using the DeltaSuit. Failure to do so can result in discomfort or pain.

- Always use the DeltaSuit with care.
- Make sure that the DeltaSuit is adjusted properly before every use.
- Stop using the DeltaSuit when experiencing discomfort or pain.
- Do not wear any tools below the DeltaSuit.

What to do in case of an emergency and exceptional situations

NOTICE

Consult your facilities security officer to ensure internal compliance with all applicable regulations.

In case of an emergency:

- Do not remove the DeltaSuit unless it is absolutely necessary.
- Make sure you are safe before assisting others.
- Follow your emergency plan.
- Get your emergency kit.

For questions or more information on how to use the DeltaSuit safely in your company please contact your supplier or Auxivo AG.

Unpacking the DeltaSuit

Unpack the DeltaSuit. Dispose of the packaging and packaging waste in a correct manner. Keep the textile bag for washing and storing of the DeltaSuit.

Make sure that the package contains the following items:

- DeltaSuit exoskeleton
- User manual
- Washing and storage bag

Checking the DeltaSuit

WARNING

For safe and effective use, each back structure must be correctly and fully inserted inside each vest pocket, and properly attached to the vest's shoulder attachment buckles.

Before each use, check that the shoulder support module and the back support module are correctly attached to the vest and textile covers are well connected to the arm cuffs.

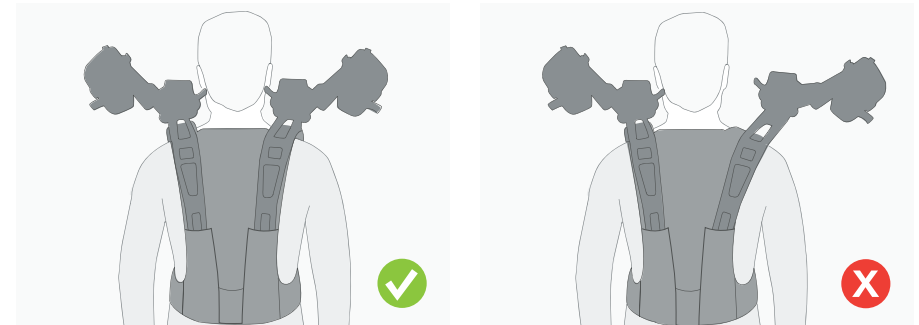

1. Check that each back structure is correctly and fully inserted inside each pocket on the back of the vest. Make sure there is no empty space in the bottom of vest pocket.

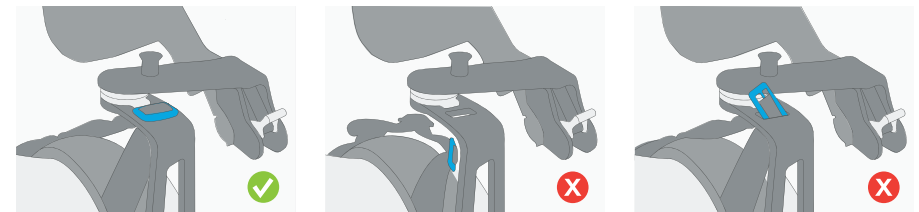

2. Check that each shoulder attachment buckle is correctly attached to the top of each back structure.

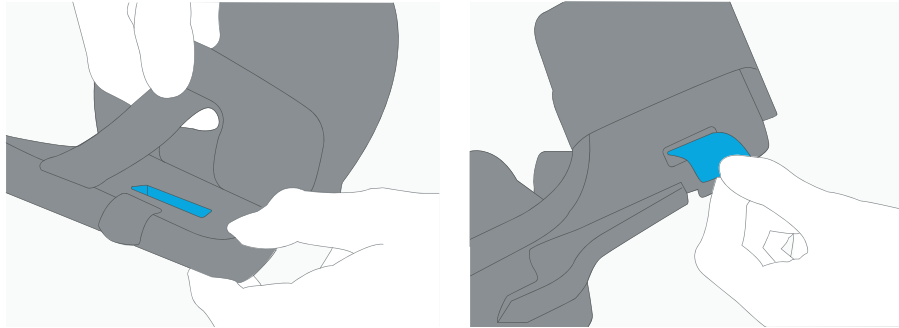

3. Check that the arm cuff textile cover is correctly attached. The Velcro should be closed through the hole.

Preparing the DeltaSuit for use

⚠ WARNING

Check the DeltaSuit for damages before putting it on.

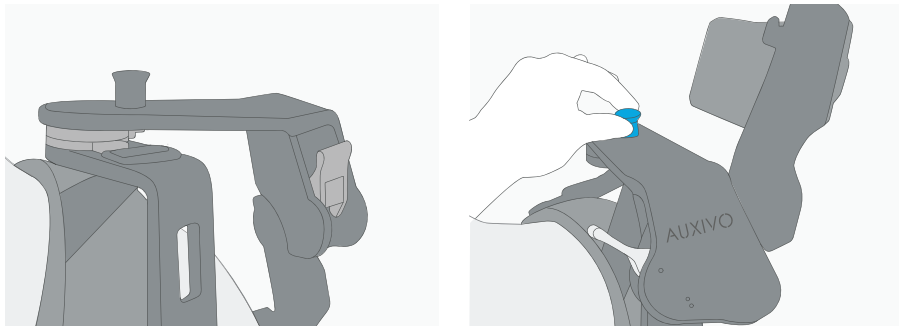

Lock the shoulder joints:

- With one hand, pull up and hold the locking pin.
- With the other hand, rotate the arm cuff towards the back until it stops against a mechanical end stop.
- Release the locking pin.
- If the arm cuff can still be moved, repeat the steps.

Open all buckles and release all straps to the maximum length.

Adjusting the support level

⚠ WARNING

The support level switch is spring loaded and snaps with high velocity when released before it reaches one of its end positions.

When switching between the two support levels, make sure to hold the switch until it fully reaches its end position, to avoid that it hits or pinches your fingers.

Adjust the support level before putting on the DeltaSuit. If the support level needs to be adapted while wearing the DeltaSuit, first take off the DeltaSuit, or ask for help from someone who knows the DeltaSuit well.

Objective: select support level 1 or 2 safely and correctly.

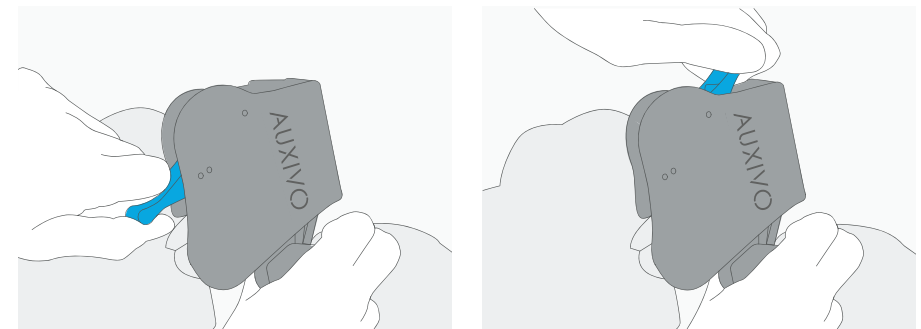

To increase to the higher support level 2, pull the blue support level switch all the way down until it reaches its end stop. Be careful not to let go too early, as this would cause the support level switch to snap back up at high speed, potentially hurting your fingers.

To reduce to the lower support level 1, guide the blue support level switch to the upper position until it reaches its end stop.

Putting on the vest

⚠ WARNING

Putting on the vest when the shoulder joints are not locked may cause the moving arm cuffs to obstruct or collide with user's head and face. Detailed instructions on how to lock the shoulder joints can be found in section 7 *Preparing the DeltaSuit for use*.

⚠ CAUTION

For safe and effective use, the vest should be correctly adjusted to the upper body.

Objective: to wear the vest comfortably and safely, with sufficient stability..

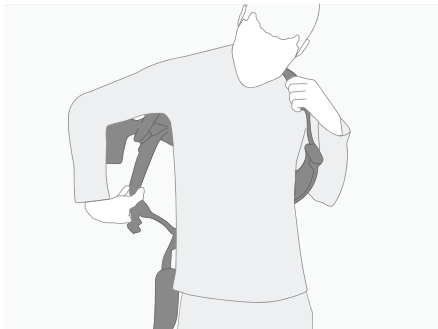

Put on the vest like a backpack.



Close and tighten both chest belts. The removable middle pad for the lower chest belt is provided for additional comfort.

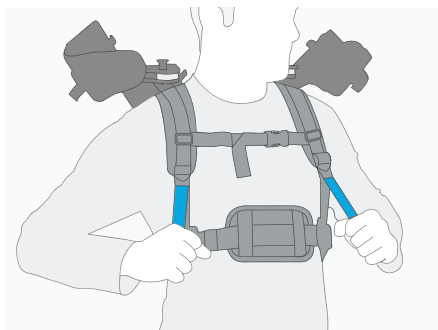

Adjust the vest height by tightening and loosening both shoulder straps. Make sure there is a gap between the shoulder joints and your shoulders to avoid pressure.

Unlocking the shoulder joints and donning the arm cuffs

⚠ WARNING

Do not pull the arm cuff down before shoulder joint is unlocked, all vest straps are closed and adjusted to size.

Pull down the arm cuff by holding on the rigid part.

Be careful when pulling down the arm cuff, which is spring loaded and thus snap at high velocity when released before your arm is correctly placed and fully resting in the arm cuff.

Make sure to hold and not let go of the arm cuff until your upper arm is correctly placed and fully resting on the arm cuff.

Before you start working, make sure your arms are correctly placed on the arm cuffs, which have been closed and adjusted to size. Check that the arm cuff loops are fully inserted in the hooks and that the Velcro adjustment straps are fully closed, and adjusted to size.

⚠ CAUTION

Make sure to unlock the shoulder joint before pulling the arm cuff down and placing arm in it. Wearing the arm cuff while the shoulder joint is locked will restrict your movement severely.

Objective: to safely put on and comfortably wear the arm cuffs.

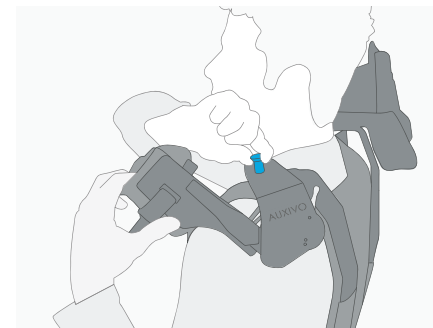

Pull up the locking pin to release the shoulder joint.

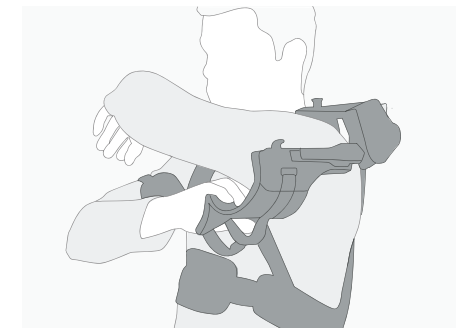

Using the opposite hand, hold the rigid part of the arm cuff, gently move it to the front and pull it down slowly. Hold it carefully while placing your upper arm on the arm cuff.

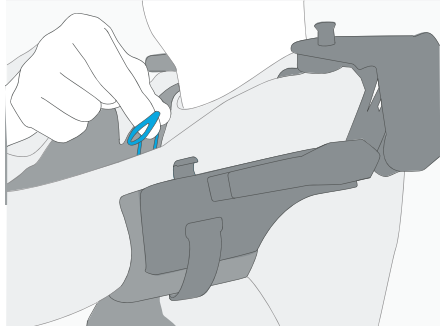

Position the arm cuff above your elbow, wherever it feels most comfortable. While keeping your arm high, use the opposite hand to close the arm cuff by connecting the arm cuff loop and the hook.

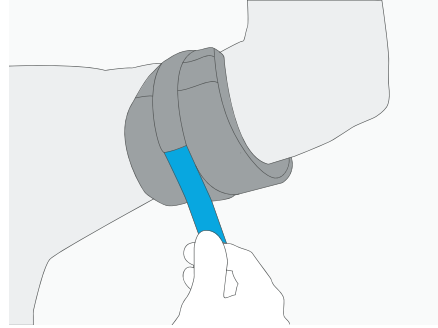

Tighten the arm cuff in 3 steps: detach the arm cuff adjustment strap, pull to tighten, and reattach.

Adjusting the shoulder joint position

⚠ CAUTION

For safe and effective use, the vest should be correctly adjusted to the upper body.

Objective: to ensure that the DeltaSuit shoulder joint is positioned correctly.

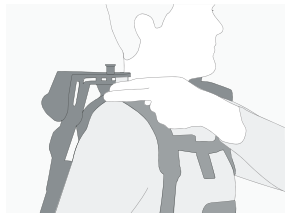

Check that two or three fingers fit in the gap between the DeltaSuit shoulder joint and vest.

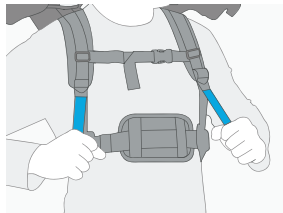

If the gap is too small, increase the vest height by tightening both shoulder straps. If the gap is too large, lower the vest by loosening the shoulder attachment straps.

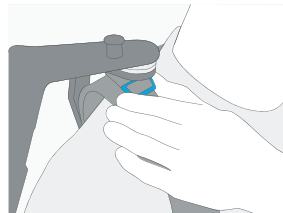

If after adjusting the vest height the gap is still too small, tighten the shoulder attachment strap. This will increase shoulder stability and prevents pressure points.

Checking and adjusting for an optimal fit

Objective: To wear the DeltaSuit with an optimal fit, the best support effect, and maximum comfort.

- The vest should sit tightly on the upper body, but comfortable enough to allow for free movements and breathing. If it is too loose, tighten the chest belts further. If you feel any discomfort, loosen the chest belts slightly.
- Check that you can raise both your arms forward. If not, make sure that arm cuffs are not locked.
- Check that when you lift your arms around, the DeltaSuit shoulder joints are stable and positioned at about 2-3 fingers above the vest. If too low, shorten the shoulder straps in the front. If too high, loosen the shoulder straps in the front. Additional stability can be achieved by tightening and loosening the shoulder adjustment strap that connect the shoulder module with the vest above your shoulder joint.
- Check that the arm cuffs are not sliding down to your elbow. If so, re-position and tighten arm cuffs further. Check if the arm cuffs are too tight. If yes, loosen arm cuffs.
- Make sure the thigh cuffs are tight but still comfortable to wear. The ideal degree of tightness of the cuffs is reached when a flat hand can be pushed between the thigh and the cuff without much effort.

When friction or pressure points occur during use, corrections can be made by readjusting the vest and arm cuffs. This might be necessary especially during the first hour of use, when the DeltaSuit “settles” after putting it on, or when you change your workplace and you switch e.g. from standing work to working on your knees.

⚠ WARNING

Stop using the DeltaSuit when experiencing signs of overheating, like heavy sweating, dizziness or fatigue.

Securing loose straps

⚠ WARNING

Use the safety thread-back loops or Velcro straps to properly store each loose strap end to prevent clinging to protruding objects and getting stuck in moving parts, machines, or vehicles.

- Ensure that all straps are guided through the thread-back loops. The thread-back loops should be positioned away from the buckle as far as possible.
- Ensure that both the Velcro arm cuff adjustment straps are closed.

Taking off the DeltaSuit in the right order

⚠ WARNING

When taking off the DeltaSuit, for each side, first open arm cuff and take off arm carefully, before conducting any other steps.

Do not take off the vest while your arms are still inside the arm cuffs.

Handle the DeltaSuit gently and store it safely.

First, take off and lock the shoulder support module for each arm, one at a time:

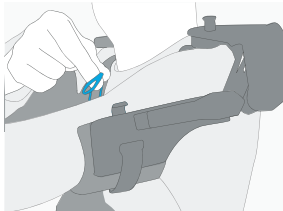

Using the opposite hand, open the arm cuff by detaching the hook.

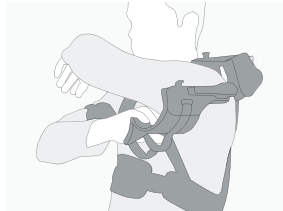

Keep arm high and hold the arm cuff, while slowly and carefully removing your arm from the arm cuff.

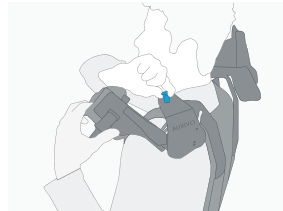

Lock shoulder joint: with one hand, pull up and hold the locking pin. Rotate the arm cuff towards the back until it stops against a mechanical end stop. Release the locking pin. If the arm cuff can still be moved, repeat the steps.

Then take off the thigh cuffs and vest:

- Check that both shoulder joints are locked.
- Open all release buckles.
- Take off the vest.
- Air dry and store afterwards.

General care

- Always handle the DeltaSuit with care.
- Avoid contact between sharp or piercing objects and the DeltaSuit.
- Keep your DeltaSuit clean from oil and chemicals that could damage it.
- Ensure that the DeltaSuit is stored in a dry and ventilated place without direct sunlight.
- When working in environments with dust, dirt, or other small particles, clean after use.

Inspections

⚠ WARNING

Perform a visual inspection at least every 1 month to ensure proper function of the DeltaSuit. Keep a log to record inspections. After identifying a possible problem, e.g. a damaged part, remove the DeltaSuit from operation and contact your supplier or Auxivo AG for further assistance.

When something does not feel right while working, take off the DeltaSuit and perform a visual inspection before continuing to use.

When the DeltaSuit suffers from high impact force, such as falling on the ground, perform a visual inspection before continuing to use.

To conduct a visual inspection, check all the components in the list below:

Vest

Check for signs of damage on the vest pockets, buckles, and straps.

Shoulder Elastic Energy Storage (EES)

Check for signs of wear, deformation, or tear on the shoulder EES on each side, using the following steps:

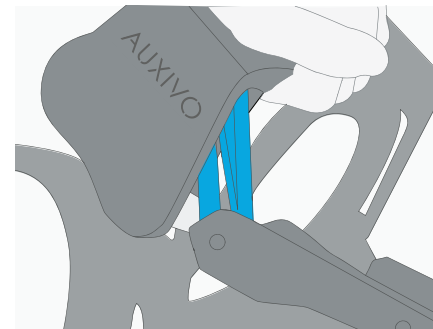

Visually inspect the shoulder EES from the front side by pulling down the arm cuff, while holding the shoulder joint. Rotate to see all sides, as well as the elastic bands inside the plastic housing.

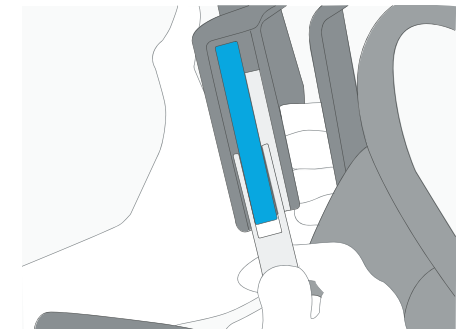

Visually inspect the shoulder EES from the back side by pulling down the support level switch to level 2. Inspect the shoulder EES above the support level switch.

Cleaning, Care and Maintenance

Arm cuffs

Check for signs of damage on the plastic part of the arm cuffs. Check for signs of damage to the loop of the arm cuff textile cover.

Shoulder support module cover

Check for signs of damage on the plastic cover of the shoulder support module.

Shoulder attachment buckle

Check for signs of wear and tear on the shoulder attachment buckles and straps.

⚠ WARNING

After identifying wear and tear or other damages, remove the DeltaSuit from operations. Contact your supplier or Auxivo AG for further assistance.

Cleaning the DeltaSuit

NOTICE

Incorrect care can lead to damages.

Do not use an air gun to clean any parts of the DeltaSuit.

To clean the DeltaSuit, please follow these steps to prevent damage to the DeltaSuit:

Separate the shoulder support module from the vest:

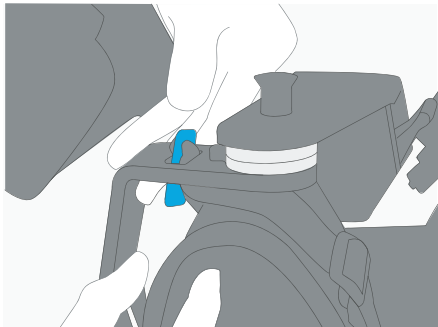

Push the loop of the connecting strap to one side and pull it away from the EES hook.

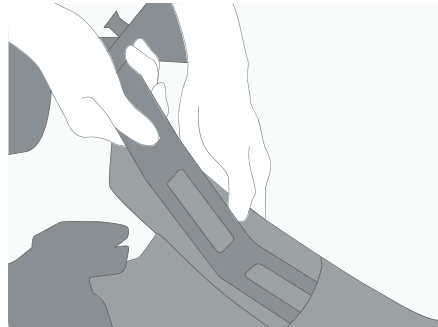

When the loop slips out of the EES hook, pull it out. Repeat the process for the other connection on the other back EES.

Cleaning, Care and Maintenance

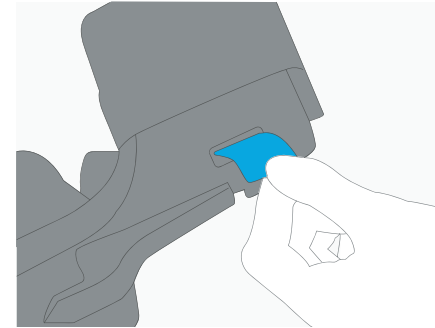

Take off each arm cuff textile cover by detaching the Velcro strap on the bottom of the arm cuff and passing it through the slot next to the arm cuff hook.

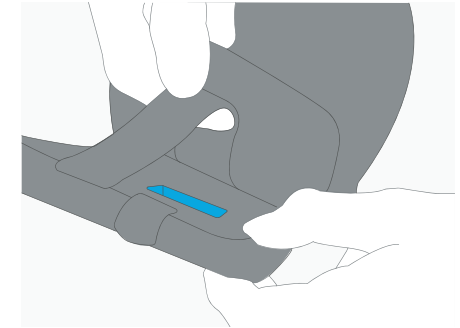

Pull the arm cuff textile cover off the arm cuff.

Clean textile parts:

- Close all release buckles of the vest.
- Close all straps and loops on both arm cuff textile covers.
- Put into a washing bag.
- Machine wash the textile components at 30°C. Do not use fabric softener. Use mild detergent.
- Wash separately. Only gentle spinning. Do not tumble-dry.
- Air dry the textile components. Make sure that it is fully dried before using it.

Clean non-textile parts:

- Wipe all surfaces with a damp cloth and air dry.
- Store safely until the textile parts are washed and ready.

Re-assemble all parts:

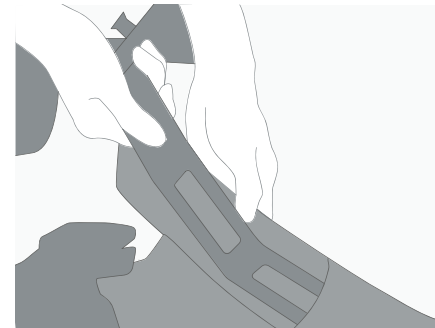

Insert each back structure into the correct vest pocket. Make sure that there is no empty space in the bottom of each vest pocket.

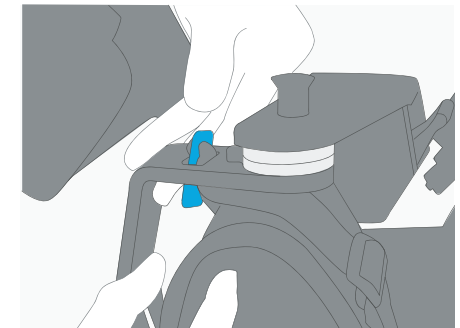

Attach each shoulder attachment buckle to the slot on each back structure.

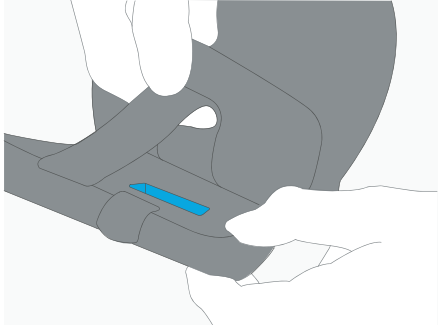

Attach arm cuff textile cover on each arm cuff.

⚠ WARNING

After assembly inspect to ensure that all parts of the DeltaSuit are correctly assembled for the next use, as described in section 7 *Checking the DeltaSuit*.

Multiple users for one DeltaSuit

⚠ WARNING

To ensure safety and comfort, the DeltaSuit should be adjusted to every new user. Instructions on adjustment and customization can be found in chapter 7 *Preparation and Use*.

When the DeltaSuit is being used by multiple users, the DeltaSuit should be properly cleaned and washed in between users. Information on cleaning the DeltaSuit can be found in section 7 *Cleaning the DeltaSuit*.

Disposal

Dispose of the device and the packaging according to local regulation to avoid environmental and public health hazards. The packaging is made of environmentally friendly materials, which may be disposed of through your local recycling facilities. The recycling of materials contributes to the conservation of natural resources.

Liability

Auxivo AG cannot be held liable for:

- Personal injury or damage to property caused by not following the instructions and warnings in this handbook.
- Damage caused by changes and/or alterations to the DeltaSuit.
- Wear and damage as a result of improper use.
- Damage caused by the use of non-original product parts, e.g. replacement parts.

Warranty

Auxivo AG warrants that the DeltaSuit has the functions described in this handbook and is free from defects in material that eliminate or substantially reduce its functions upon delivery during a sending-in warranty period of 1 year. However, the DeltaSuit also contains consumables (see section 7 *Consumables*) that must be replaced by the customer regularly at their own costs, depending on use and are not covered by the 1-year warranty period. If an DeltaSuit has defects covered by the warranty, the supplier or Auxivo AG will replace the defective DeltaSuit or defective parts of DeltaSuit. This warranty shall be applicable only if the customer has inspected the DeltaSuit and a claim pursuant to this warranty is made in writing to the supplier or Auxivo AG within 14 days after delivery stating the serial number of the defective DeltaSuit, the date such DeltaSuit was delivered and a description of the defect. Subsequently, the defective DeltaSuit must be returned to the supplier or Auxivo AG.

No warranty is given in relation to DeltaSuits that have been repaired or altered by anyone else than Auxivo AG, nor DeltaSuits that have been subject to use contrary to this handbook, to negligence, to an accident or to misuse.

This warranty is in lieu of all warranties of Auxivo AG, express or implied.

For replacement parts or warranty issues, please contact your supplier or Auxivo AG.

EC Declaration of Conformity

EC Declaration of Conformity

(DEU) EG-Konformitätserklärung (ESP) Declaración de conformidad (FRA) Déclaration de conformité (ITA) Dichiarazione CE di conformità (NLD) Verklaring van overeenstemming (PRT) Declaração de conformidade

Manufacturer: Auxivo AG
Address: Sonnenbergstrasse 74
8603 Schwerzenbach
Switzerland



Product Identification Passives industrielles Exoskelett „DeltaSuit“

The product described above, as presented, complies with the provisions of the following directives:

2006/42/EG Machinery Directive

Conformity with the directives is ensured by applying the following harmonized standards:

2006/42/EG	EN ISO 12100	Safety of machinery - General principles for design - Risk assessment and risk reduction
	EN 1005-3+A1	Safety of machinery - Human physical performance - Part 3: Recommended force limits for machinery operation

Schwerzenbach, 31.10.2023 Ort, Datum	Dr. Volker Bartenbach CEO Auxivo AG	Dario Bee Product Engineer Auxivo AG
---	--	---

Copyright

Issue: October 2023

© Auxivo AG

The content of this document
are protected by copyright.
All right reserved.

Auxivo and DeltaSuit
are registered trademarks
owned by Auxivo AG.

Regardless of the purpose, use
of these trademark is
prohibited without the written
permission of Auxivo AG.

Technical changes, errors and
omissions without prior notice.

Auxivo AG
Sonnenbergstrasse 74
8603 Schwerzenbach
Switzerland

info@auxivo.com
+41 77 250 35 31

auxivo.com

AUXIVO